

Benewake TF-NOVA

Datasheet



TF-NOVA is a small size, line pattern laser beam LiDAR developed by Benewake, which is particularly suitable for applications such as obstacle detection, presence activation trigger. Multiple parameters are available for customers to customize and configure to meet various application requirements.

Technical Specifications

Measurement Performance	
Detection range ^①	≥14m @90%reflectivity, 0Klux ≥13m @10% reflectivity, 0Klux ≥7m @90% reflectivity, 100Klux ≥4m @10% reflectivity, 100Klux
Blind zone ^②	≤ 0.1m
Accuracy ^③	± 5cm @ 0.1-4m
Repeatability ^②	< 1cm (1 sigma) @ 0.1-4m
Distance resolution	1cm
Default frame rate	Default 100Hz, 1-900Hz customizable
Optical Parameters	
Light source	VCSEL
Central wavelength	905nm
FoV of laser emission ^③	Typ. 14°×1°
Eye safety	Class 1 Eye-safe[EN60825]
Mechanical/Electrical	
Average power consumption ^④	< 500mW
peak current when starting ^④	< 850mA
Start-up time	< 1s
Power supply	DC 5±5%V
Operating temperature	-25°C ~ +70°C

Storage temperature	-30°C ~ +80°C
Dimensions	TYP. 26.5x 21.05 x 12.0mm ³
Weight	<5g
Connector	1.25mm-5P
Protection Level	N.A.
Front window protection level	IP65
Cable length	10cm

Communication Protocol

Communication Interface	UART, IIC, I/O
Baud rate	Default 115200
Data bit	8
Stop bit	1
Parity	None

Dimensions (Unit: mm)

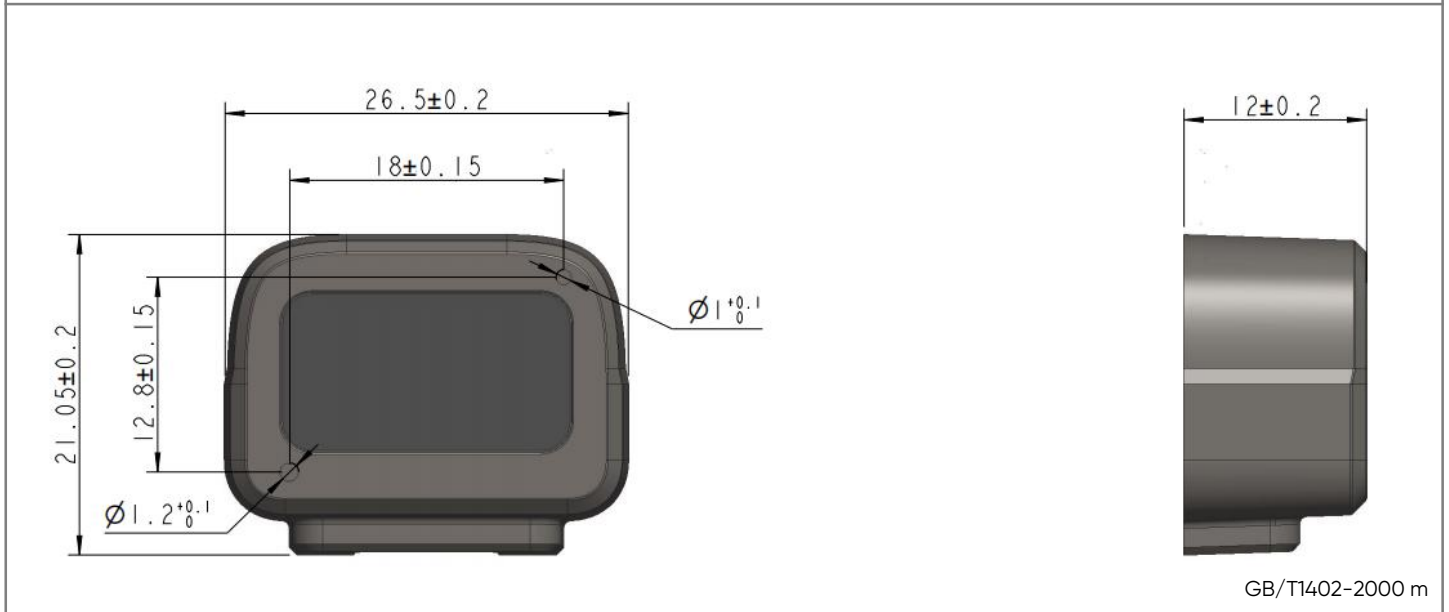

Notes to the specifications:

- ① The measurement range is measured when all light spots are placed on the target board, at 25 °C.
- ② The parameter is measured at 25 °C, 0Klux, when all the light spots are placed on the target board with a reflectivity of 10%.
- ③ This angle is the design divergence angle of the laser spot. The actual field of view angle that can trigger distance measurement depends on specific conditions such as the measured object and background. Please confirm according to the specific application.
- ④ Measured at 25 °C, changes in conditions may cause variations in the measurement results.

Declaration: The copyright of this specification belongs to © Benewake (Beijing) Co., Ltd. is not allowed to copy, modify, delete or translate the content of this specification without written permission from Benewake. Our product is constantly improving and updating, so the specifications of TF-NOVA product may change. Please refer to the latest version released by Benewake.